



INSIGHTS

FOR MASONRY DESIGN

Finite Element Modeling, Analysis, and Design for Masonry

Software programs for structural engineers continue to escalate in complexity as we become increasingly reliant on such tools. They increase accuracy in our analysis and efficiency during the design process. To solve these complex problems efficiently, and to gain a more in-depth understanding of the elements being analyzed, a greater number of structural engineers are using Finite Element Analysis (FEA). Of course, each of the different FEA programs have their own idiosyncrasies which require us to pay close attention when we move from one program to another.

Introduction

.....

What exactly is finite element analysis? It is the process of reducing (simplifying) a problem with infinite degrees of freedom to a finite number of elements with unique material properties. FEA programs are able to resolve even the most complex of problems in a reasonable amount of time. The process of finite element modeling and analysis is an approximate solution which closely mimics an actual structure in a way that allows structural engineers to safely design for the stresses, forces, and deflections that are determined from these methods.

Some of the more commonly used software programs for FEA with masonry design are RAM Elements (soon to be released as STAAD(X) from Bentley Systems, Inc) and RISA Floor/RISA 3D (from RISA Technologies). Other FEA programs with high end analysis features, such as SCIA Engineer, are important tools for structural engineers because they offer more options for creating elements that more closely represent the actual elements behavior.

General Comments about Finite Element Modeling

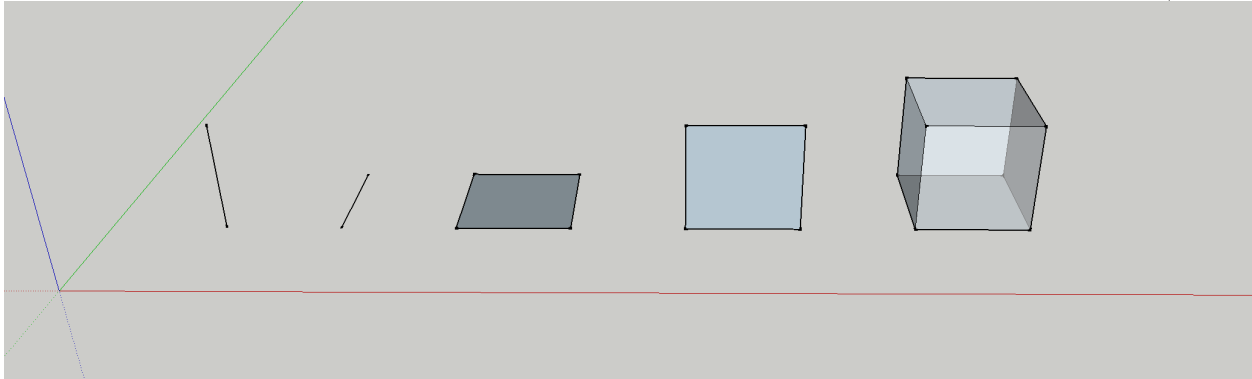

Finite element models are created by modeling line, plate/shell, and solid (or brick) elements, with associated end nodes.

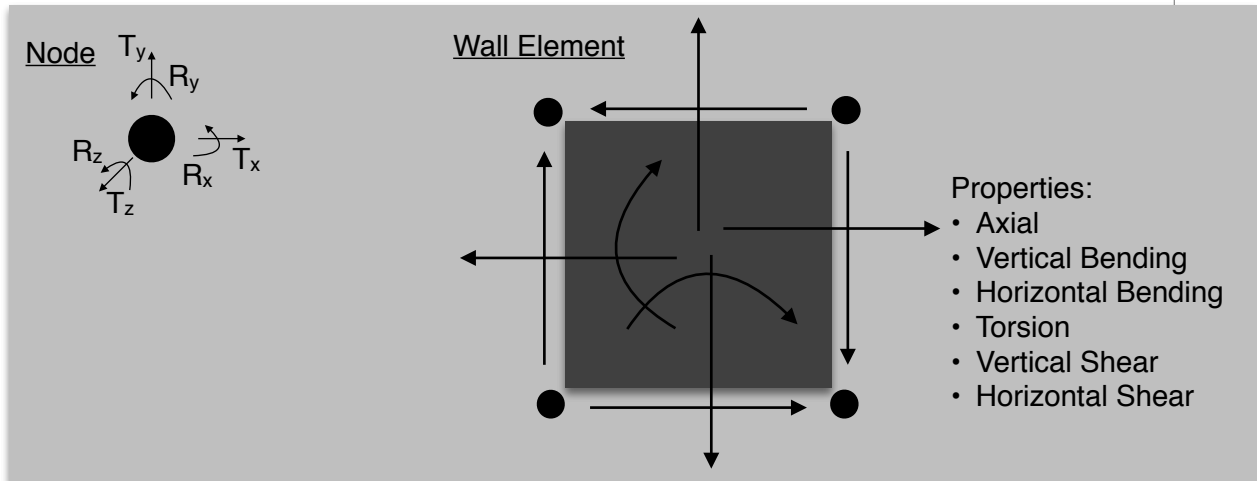

Figure 1: Line elements | Plate/shell elements | Solid (brick) element

Figure 2: Node degrees of freedom and wall element properties

In structural engineering, most problems can be modeled reasonably with one-dimensional line elements, or two-dimensional plate or shell elements. More complicated three-dimensional elements, such as solid (or brick) elements, have not been commonly used in most commercial software available for structural engineering today. When creating a model, these line and plate/shell elements with their associated properties are defined, as well as end nodes defined with translational or rotational degrees of freedom. The properties designated to the line and plate elements must be defined to associate a reasonable stiffness with each element. Columns and beams (not masonry lintels) are able to be modeled with line

elements, and walls and slabs are modeled with plate/shell elements. Many software programs allow the engineer to define the geometric boundaries of entire wall panels from movement joint to movement joint, and discretize those large geometries into smaller finite elements by a process called meshing. Sometimes meshing is a manual process, and other times programs will offer automatic meshing.

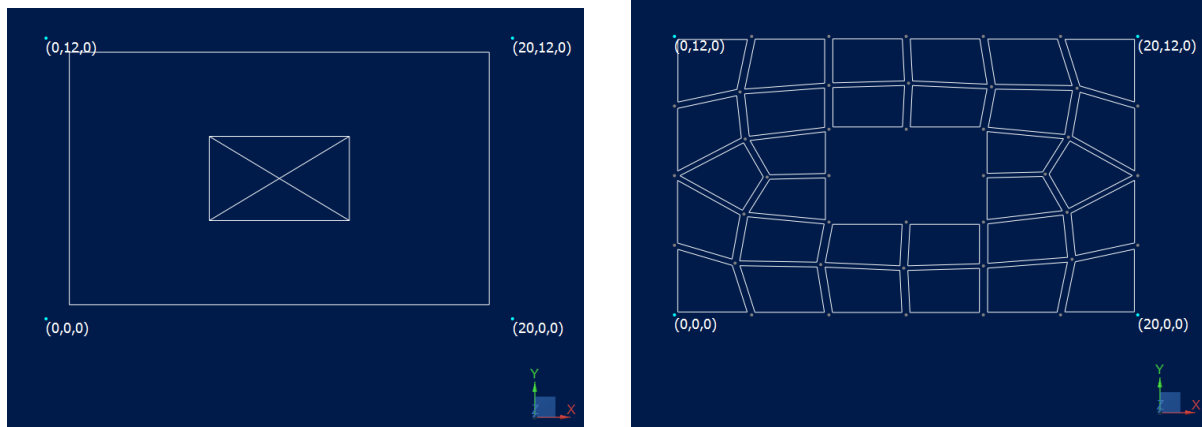

Figure 3: Wall Geometry with opening | Wall discretized into finite elements
example of automatic meshing from RAM Elements

Pre-Processing and Masonry Modeling

Many of the analyses used today assume thin plate theory for the plate elements along with linear elastic behavior for the elements. The elasticity of material is described by a stress-strain curve, which shows the relation between internal force per unit area and the relative deformation. Linear elasticity is a simplification assuming linear relationships between the components of stress and strain which is valid only for stress states that do not produce yielding or fracture. Reinforced masonry and other reinforced concrete elements have the complication of not being elastic. Therefore, once a concrete element cracks, modeled steel reinforcement is then engaged in these elements. Of course, masonry is made up of several different concrete components which closely mimic this behavior when it is reinforced. Many times finite

Name	SF2D1
Description	
Type	Bending
Correction factor for D11	1.000
Correction factor for D12	1.000
Correction factor for D22	1.000
Correction factor for D33	1.000

Figure 4: Example of bending modification factors available in SCIA Engineer

element software gives us element modification factors to account for the reduced stiffness of the concrete or masonry element once it has cracked. In some programs this factor is automatically applied, in some it must be manually defined, and in others it is not an option. Some programs offer multiple element modification factors including: bending in each direction, torsion, shear, and axial deformations. One must confirm that the element modification factor used to account for the reduced stiffness from cracking only applies to the bending stiffness in the the direction of the cracked behavior, and is not used with the shear stiffness or the axial stiffness of the element.

When the analysis program being used does not have an appropriate element modification factor, an adjustment to the actual properties of the element might be necessary. An adjustment may mean modifying the elastic modulus of the element. The elastic modulus is used to determine the stiffness for the element in each of the deformation categories, therefore an adjustment will impact the element in all properties of bending, shear, and axial deformation. This type of modification must be used with caution and may not always be appropriate.

Masonry is unique in that it is often reinforced in the vertical direction but left unreinforced in the horizontal direction. Therefore, the element may only span horizontally if it remains un-cracked in that direction. If the anticipated design demand stresses are beyond the allowed cracking stresses, users should consider reducing stiffness by using a reduced element modification factor. Again, this emphasizes the need for the modification factors to be considered separately in each orthogonal direction. When all of the factors are equal, the slab element behaves as an isotropic material, a material having the same properties in all directions. When the factors are different from each other, the slab elements behave as an orthotropic material, a material having different properties along its three perpendicular axes.

Care must be used when setting these stiffness factors. With certain combinations of factors, the structure can become unstable and the results can become unreliable. Also, the interaction of the stiffness factors may be more complex than it appears upon first inspection.

Masonry design also requires custom material types within software to account for attributes that are unique to this material, such as grouting only reinforced cells (partial grouting). This will affect how we must model masonry elements. Partial grouting affects both the loading aspect (from the self-weight contribution) of the finite element modeling as well as the stiffness of the masonry finite elements. There are some programs, such as RISA 3D, that account for partial grouting of the masonry wall, otherwise modifications must be made to the finite element properties (such as altering the actual thickness of the element). Again, there are pluses and minuses associated with modifying the thickness of an element to accommodate for the actual condition of partially-grouted masonry. The axial and shear stiffness of the wall may be be accurately modified, however the reduction to the bending stiffness of the finite elements would not be accurate and result in elements that are much weaker than they actually are in a real partially-grouted wall. Therefore, engineering judgment must be used when the software does not account for partial grouting and we are left to make modifications which may bring unintended consequences. It is also important to recognize that overall geometric wall modeling for masonry walls must account for the physical separation between walls due to control joints. RAM Elements allows for quickly separating linked wall panels (panels that share end nodes) into separate wall panels with unique end nodes. Whether

there is a tool to create this separation, or the walls are manually modeled separately with unique end nodes, separation in the finite element model is required to ensure each wall is able to act independently from one another.

There are a few items to consider regarding finite element meshing. Finite element programs are based on plate elements that are quadrilateral (four nodes per plate/shell), and the ideal shape is a square. Without going into the finite element theory of why this is ideal, it is important to know that the further plate/shell elements are from a square, the less accurate the finite element approximations become. When considering the ideal size of the plate/shell elements when meshing (manually or automatically) a wall geometry, we need to consider the accuracy of the results, computational processing time, and the material being modeled. When considering accuracy, the finer the mesh (more smaller plates/shells), the higher the probability that the elements will be square, and the results will be more accurate. This is especially true in complex models. However, the smaller the mesh, the more plates/shells and nodes, the more time will be required for analysis. Even with the advances that have been made in software, finite element models with a very fine mesh can make computational time unreasonable. Lastly, considering the material properties, it could be argued that concrete and masonry have an inherent minimum element size due to what is referred to as the “chunkiness” of concrete. It is unreasonable to have differential movement between nodes that are closer together than the actual thickness of the masonry element. This is similar to evaluating one-way shear no closer than depth of concrete element away from a support. Considering all of these size recommendations, there is also the point of diminishing returns. A model's approximate solution starts to converge on a solution, and using a finer mesh does not result in any changes to the overall solution. In general, the recommended maximum plate/shell size would be the span distance divided by ten and the minimum plate size should be no less than the thickness of the masonry wall. For example, twelve-inch thick, thirty foot tall wall would have a minimum plate size of twelve inches and a maximum plate size of three feet (span/eight). Of course, there may be times when these guidelines must be reevaluated for unique situations, but in general they have been found to be a good starting point for determining plate/shell size in finite element models for walls.

As you can see, much care is involved when modeling masonry wall systems with finite element analysis programs to ensure all of the boundary conditions, stiffnesses of the elements, and weights of the elements are accurately accounted for in the development of the finite element model.

Some may wonder if all of this effort worth it for a masonry wall. I would argue that it is definitely necessary if we want to understand the true behavior of complex wall systems, such as in-plane shear wall capacity of perforated shear walls (wall panels with openings in the middle), and gain an even better understanding of the out-of-plane behavior in walls with openings.

Of course, modeling masonry finite elements is also essential in all of the following lateral analysis scenarios as well:

- Lateral dynamic analysis for any building with masonry lateral-resisting elements. Appropriate load and stiffness is required to understand the true dynamic behavior, which yields building fundamental periods

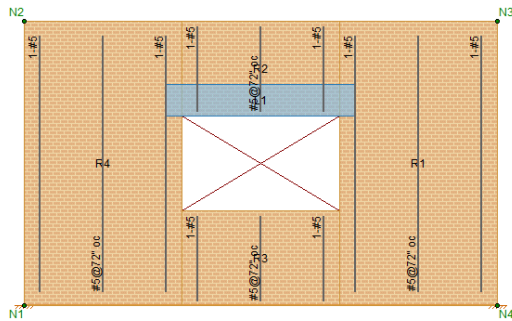
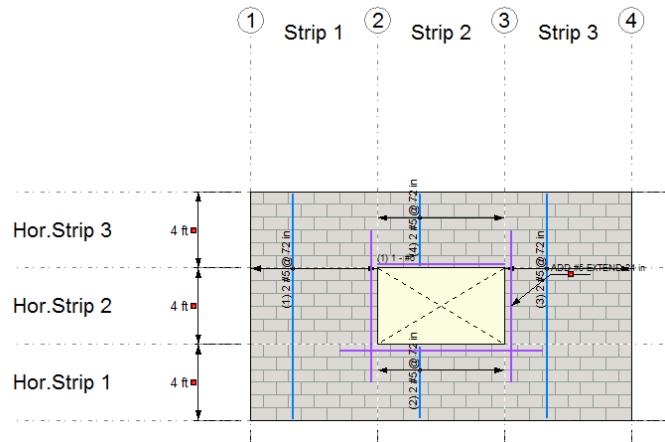

Figure 5: image above from RISA showing wall areas, image to the right of RAM Elements showing wall strips



- Lateral analysis load distribution (through rigid or semi-rigid diaphragms) between masonry and other systems or materials, such as concrete or structural steel frames

Once the finite element model has been defined and the analysis is complete, then we need to turn our attention to the task of post-processing of finite element results and performing the design.

Post-processing and Design

The next challenge involves taking the results from the finite element model and analysis and converting them into information that can be compared to code-defined maximum stresses or forces that determine the capacity of the masonry wall. Finite element programs for masonry combine the results of several plate/shell elements within geometric areas or strips of the model as defined by the user. Areas above openings are rationalized into an area that will be checked against lintel capacities. Engineers must study software programs and their combination (summation) of finite element results and make modifications when necessary.

Generally, structural engineering software will check for in-plane bending and shear capacity, out-of-plane bending and shear capacity, and axial capacity of masonry walls. Lintel shear and bending capacities will also be evaluated. Lintels (not in a finite element model) have traditionally been checked by assuming a simply supported "beam" element. Finite element approximation and design of the area above the openings are fundamentally different as the plates/shells in this area are interlocked by sharing nodes with the other surrounding elements of the wall. When evaluating bending moment in walls, often software programs evaluate only vertical bending and do not evaluate assess for horizontal bending and shear of masonry walls. Therefore, the user is left to manually check the horizontal bending moment against an unreinforced masonry bending capacity. If horizontal bond beams are used within a masonry wall, the horizontal bending moment may be manually checked against a reinforced bending capacity.

One may find some programs may not be able to correctly define the finite element model. If the program does not, the designer must decide if manual modifications can be made to the model without adversely affecting its other attributes and results. Further, evaluation of the post-processing design features of programs and design checks at show that results are not always complete and must be supplemented with manual checks of the analysis results. Ultimately, careful evaluation when selecting software to be sure it is well-suited for your needs; however, additional calculations may be needed. Therefore, I would recommend thoroughly reviewing the element response to applied forces. The simplest and most revealing check can be made by animating the deflections of the elements. For example, a simply-supported wall element should have a deflected animated shape that is a simple curve, and a wall with moments fixed at the top or with a parapet (cantilevered element above the roof) should have a compound curve. To review the forces in the element, a quick manual calculation should be within 20-25% of the anticipated forces in any particular element within a finite element model. Lastly, reviewing the reactions to the applied forces is a good study to make sure the elements are being modeled properly.

Of course, we also cannot forget about the fact that the finite element models we create as structural engineers often contain other materials and elements that are connecting to the masonry wall elements within our model. It is important to consider how those elements are connecting into masonry. Consider items such as: are the beams (line elements) pinned at the end connecting into the masonry wall? Should the beam ends be offset from the centerline of the masonry wall panel? Are the shell/plate slab elements pinned or fixed to the masonry walls?

In conclusion, I strongly recommend utilizing finite element software to truly understand and effectively design your next masonry project. There are many items to consider with respect to the material properties, how the wall is supported, and how elements are connected to masonry elements. However there are very good software options for representing masonry elements which make us more accurate, more efficient, and better engineers once we learn how to use them correctly.

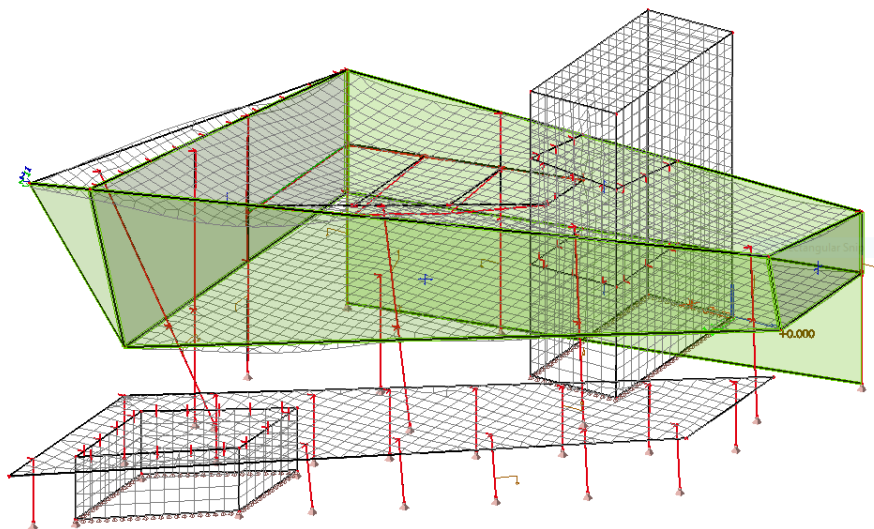

Figure 6: Example of complete finite element model with masonry walls, which has concrete slabs, steel beams connecting to the walls model from SCIA Engineer