



MASONRY INSIGHTS

written in conjunction with International Masonry Institute

Masonry Lap Lengths

Lap splice lengths for reinforcement on masonry projects are an important specification to consider on design drawings. When a project utilizes typical masonry closed-end masonry block, mason contractors will need to lift blocks over the vertical bar that projects above the bottom courses to lap with vertical bars above. The longer the lap, the more labor costs are incurred. However, designers must also ensure the proper transfer of stresses from one bar to another within the lap splice. This article hopes to clarify tips to consider while calculating lap splice (or development) lengths, and best practices for detailing lap lengths on design drawings.

According to the masonry code, **TMS 402 Building Code Requirements for Masonry Structures** (formerly MSJC), development length of reinforcement shall be the minimum of 12 inches or the length calculated by the following equation:

l_d = length of reinforcement development or splice length

d_b = diameter of reinforcement bar

$$l_d = \frac{0.13d_b^2 f_y \gamma}{K \sqrt{f'_m}}$$

f_y = reinforcement yield strength

γ = 1.0 for bars #3-#5

1.3 for bars #6-#7

1.5 for bars #8 and larger reinforcement

K = minimum (cover, clear spacing, $9 \times d_b$)

f'_m = masonry design strength

Note that for epoxy-coated bars, TMS 402 requires that development length shall be increased by a factor of 1.5.

TMS 402 also states, "Reinforcement spliced by non-contact lap splices shall not be space transversely further apart than 1/5 the length of lap, nor more than 8 inches."

wall thickness, t_w : **8 inches** reinf. spacing: **64 inches**
 wall strength, f'_m : **2500 psi** reinf. position: **centered**
 reinf. Strength, f_y : **60000 psi**

Bar	Bar diameter, d_b	γ	K	development length, l_d
#3	0.375	1	3.375	12 inches
#4	0.5	1	3.5625	12 inches
#5	0.625	1	3.5	17 inches
#6	0.75	1.3	3.4375	33 inches
#7	0.875	1.3	3.375	46 inches
#8	1	1.5	3.3125	71 inches
#9	1.125	1.5	3.25	91 inches

Example 1: DEVELOPMENT LENGTH TABLE

Based on TMS 402 Equation 6-1

The International Building Code, IBC references the TMS code, and also provides a maximum development length or lap length of 72 times bar diameter, d_b . This maximum length parameter generally only affects the development/lap lengths for larger bars or bars at each face. Refer to Example 2.

thickness, t_w : **8 inches** reinf. spacing: **48 inches**
 strength, f'_m : **2500 psi** reinf. position: **centered**
 reinf., f_y : **60000 psi**

Bar	d_b	γ	K	development length, l_d	Maximum of 72 x d_b (from IBC)
#3	0.375	1	3.375	12 inches	27 inches
#4	0.5	1	3.5625	12 inches	36 inches
#5	0.625	1	3.5	17 inches	45 inches
#6	0.75	1.3	3.4375	33 inches	54 inches
#7	0.875	1.3	3.375	46 inches	63 inches
#8	1	1.5	3.3125	71 inches	72 inches
#9	1.125	1.5	3.25	81 inches	81 inches

Example 2: DEVELOPMENT LENGTH TABLE

Based on TMS 402 and IBC

The old method of determining reinforcement laps were based on a simple formula of 48 times d_b .

This old method is too simple. In most cases the development length/ splice length based on $48*d_b$ is too long (overly conservative) for smaller bars - see Example 3 below.

thickness, t_w :	8 inches	reinf. spacing:	48 inches
strength, f'_m :	2500 psi	reinf. position:	centered
reinf., f_y :	60000 psi		

Bar	d_b	γ	K	development length, l_d	$48 * d_b$	comment
#3	0.375	I	3.375	12 inches	18 inches	too long
#4	0.5	I	3.5625	12 inches	24 inches	too long
#5	0.625	I	3.5	17 inches	30 inches	too long
#6	0.75	I.3	3.4375	33 inches	36 inches	too long
#7	0.875	I.3	3.375	46 inches	42 inches	too short
#8	I	I.5	3.3125	71 inches	48 inches	too short
#9	I.125	I.5	3.25	81 inches	54 inches	too short

Example 3: OLD METHOD COMPARISON FOR DEVELOPMENT LENGTHS, BARS CENTERED

There are also times, especially with reinforcement at each face, when development length/ splice length based on $48*d_b$ is too short (un-conservative) - see Example 4 below.

thickness, t_w :	12 inches	reinf. spacing:	48 inches
strength, f'_m :	2500 psi	reinf. position:	each face
reinf., f_y :	60000 psi	reinf. cover:	2.0 inches

Bar	d_b	γ	K	development length, l_d	$48 * d_b$	comment
#3	0.375	I	2.0 inches	12 inches	18 inches	too long
#4	0.5	I	2.0 inches	20 inches	24 inches	too long
#5	0.625	I	2.0 inches	30 inches	30 inches	too short
#6	0.75	I.3	2.0 inches	54 inches	36 inches	too short
#7	0.875	I.3	2.0 inches	63 inches	42 inches	too short
#8	I	I.5	2.0 inches	72 inches	48 inches	too short
#9	I.125	I.5	2.0 inches	81 inches	54 inches	too short

Example 4: OLD METHOD COMPARISON FOR DEVELOPMENT LENGTHS, BARS EACH FACE

Finally, adding the lap splice length to the masonry wall schedule is a good way to communicate the required lap lengths for reinforcement within masonry walls. A wall schedule is often referred to while contractors build the walls, and it is a simple, clear, and easy way to identify the required lap length.

		VERTICAL REINFORCEMENT		
WALL TYPE	THICKNESS	BAR(S) @ SPACING	LAP DISTANCE	NOTES
W ₁	8"	1-#4 @ 64" O.C.	12 inches	
W ₂	8"	2-#4 @ 16" O.C.	20 inches	
W ₃	8"	1-#6 @ 48" O.C.	33 inches	
W ₄	8"	1-#7 @ 48" O.C.	46 inches	CONSIDER REINF COUPLER
W ₅	12"	2-#6 @ 16" O.C.	54 inches	CONSIDER REINF COUPLER
$f'_m = 2500$ PSI				

Example 5: MASONRY WALL SCHEDULE WITH LAP LENGTHS

Confinement of Reinforcement

Lap splice lengths can be reduced if the lap splice is properly confined by transverse reinforcement per TMS 402. Providing a #3 or larger bar transverse to the lapped bars and within 8" from each end of the lap splice allows the lap splice length to be reduced by the confinement reinforcement factor per equation below. However, the lap splice length shall not be less than $36d_b$. The clear space between the transverse bars and lapped bars shall not exceed 1.5", and the transverse must fully develop beyond the intersection with lapped bars in grouted masonry. See Example 6 below.

$$\xi = 1.0 - \frac{2.3A_{sc}}{d_b^{2.5}} \leq 1.0$$

A_{sc} = area of the transverse bar, not greater than 0.35 in²

d_b = diameter of reinforcement bar

Figure 1 illustrates minimum requirements for confinement reinforcement per NCMA TEK 12-6a (2013).

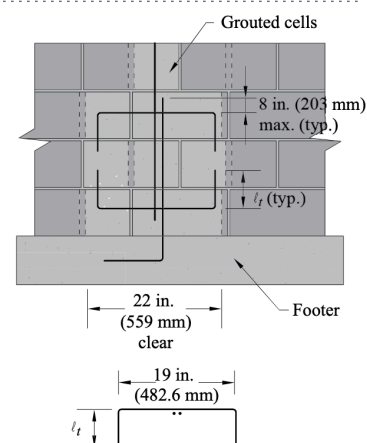

If continuous horizontal reinforcement is not otherwise provided within the end 8 in. (203 mm) of each end of the splice, confinement requirements may be satisfied by providing hooked reinforcement as detailed here. See Tables 4a through 4d for l , minimum length requirements. Hook extensions are permitted to overlap.

Figure 1: CONFINEMENT REINFORCEMENT AT LAP SPLICE PER NCMA TEK 12-6A

thickness, t_w : 12 inches reinf. spacing: 48 inches strength, f'_m : 2500 psi reinf. position: each face reinf., f_y : 60000 psi reinf. cover: 2.5 inches confinement: #4								
Bar	d_b	γ	K	ξ	original dev. length, l_d	Min of 36 d_b (from TMS)	Max of 72 d_b (from IBC)	development length, l_d
#3	0.375	1	2.5 inches	0.000	12 inches	14 inches	27 inches	12 inches
#4	0.5	1	2.5 inches	0.000	16 inches	18 inches	36 inches	16 inches
#5	0.625	1	2.5 inches	0.000	24 inches	23 inches	45 inches	23 inches
#6	0.75	1.3	2.5 inches	0.073	46 inches	27 inches	54 inches	27 inches
#7	0.875	1.3	2.5 inches	0.369	62 inches	32 inches	63 inches	32 inches
#8	1	1.5	2.5 inches	0.548	94 inches	36 inches	72 inches	51 inches
#9	1.125	1.5	2.5 inches	0.664	118 inches	41 inches	81 inches	79 inches

Example 6: DEVELOPMENT LENGTH TABLE WITH CONFINEMENT REINFORCEMENT

Based on TMS 402 and IBC

Additional Tips for Designers

Using a wall schedule is a good way to show that the same bar may have different lap lengths required in different situations, as is shown in WALL TYPE W₁ and W₂. Lap lengths do vary based on all the variables shown in the equation on page 1. Lap lengths increase when:

- Using lower f'_m
- Increasing bar size, and/ or
- Decreasing reinforcement cover or spacing distance between reinforcement

Ways to avoid long lap lengths are to use the maximum allowed f'_m , use smaller bar diameters when possible, try to avoid tight bar spacings, and try to avoid small reinforcement covers (double reinforced walls) when possible.

When there is a situation where a larger lap distance is needed (larger bars are needed, small spacing, and/ or double reinforced walls are needed) as shown in WALL TYPE W₄ and W₅, it may be advisable to consider using a reinforcement coupler instead of lapping the reinforcement bars. Reinforcement couplers can be a threaded splice coupler or a mechanical sleeve coupler. Couplers must be selected carefully as masonry cells are confined spaces and may not have sufficient space for all types of couplers.

In conclusion, considering ways to reduce lap splice lengths (use of higher f'_m , centering bars within cells where possible, selecting smaller bar diameters, confinement of laps, etc) will help towards constructibility and labor costs, possibly offsetting any additional material costs. Implementing wall, lintel, or pier schedules specifying lap splice lengths specific to reinforcement conditions in lieu of more general statements in General Notes will also lead to more efficient masonry detailing.

Detail Example

Below is an example of reinforcement lap schedule.

VERTICAL REINFORCEMENT LAP SCHEDULE

REBAR SIZE / NUMBER	LAP DISTANCE	
	8" CMU	12" CMU
#3	12	12
#4	12	12
#5	17	12
#6	33	22
#7	46	29
#8	71	44
#9	n/a	56
(2) #3	12	12
(2) #4	16	16
(2) #5	n/a	24
(2) #6	n/a	46

IT IS IMPORTANT REINF. BARS SHALL BE PLACED IN CONTINUOUS UNOBSTRUCTED CELL OF NOT LESS THAN 3" x 4" AND WITHIN MAX. TOLERANCE AS SHOWN

TOLERANCES FOR PLACING OF REINF. BARS AT EACH FACE
 PARALLEL TO WALL = $\pm 2"$
 PERPENDICULAR TO WALL = $+1/2"$ (TOWARD INSIDE)
 PERPENDICULAR TO WALL = $-1/4"$ (TOWARD OUTSIDE)

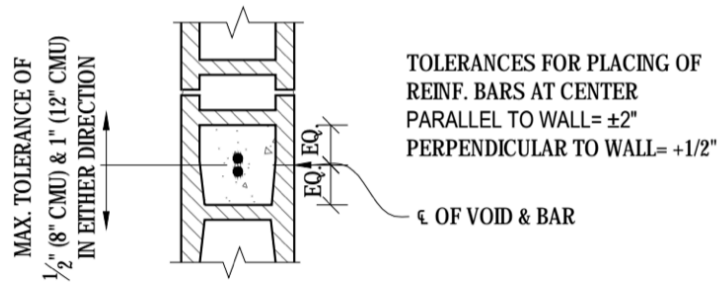
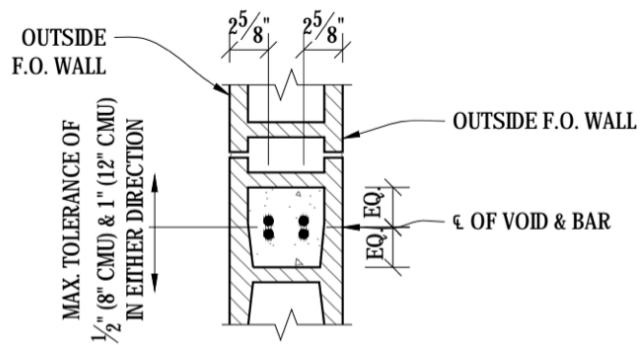

REBAR LAP AND PLACEMENT DETAIL

SCALE : 1" = 1'-0"